

FIG-1

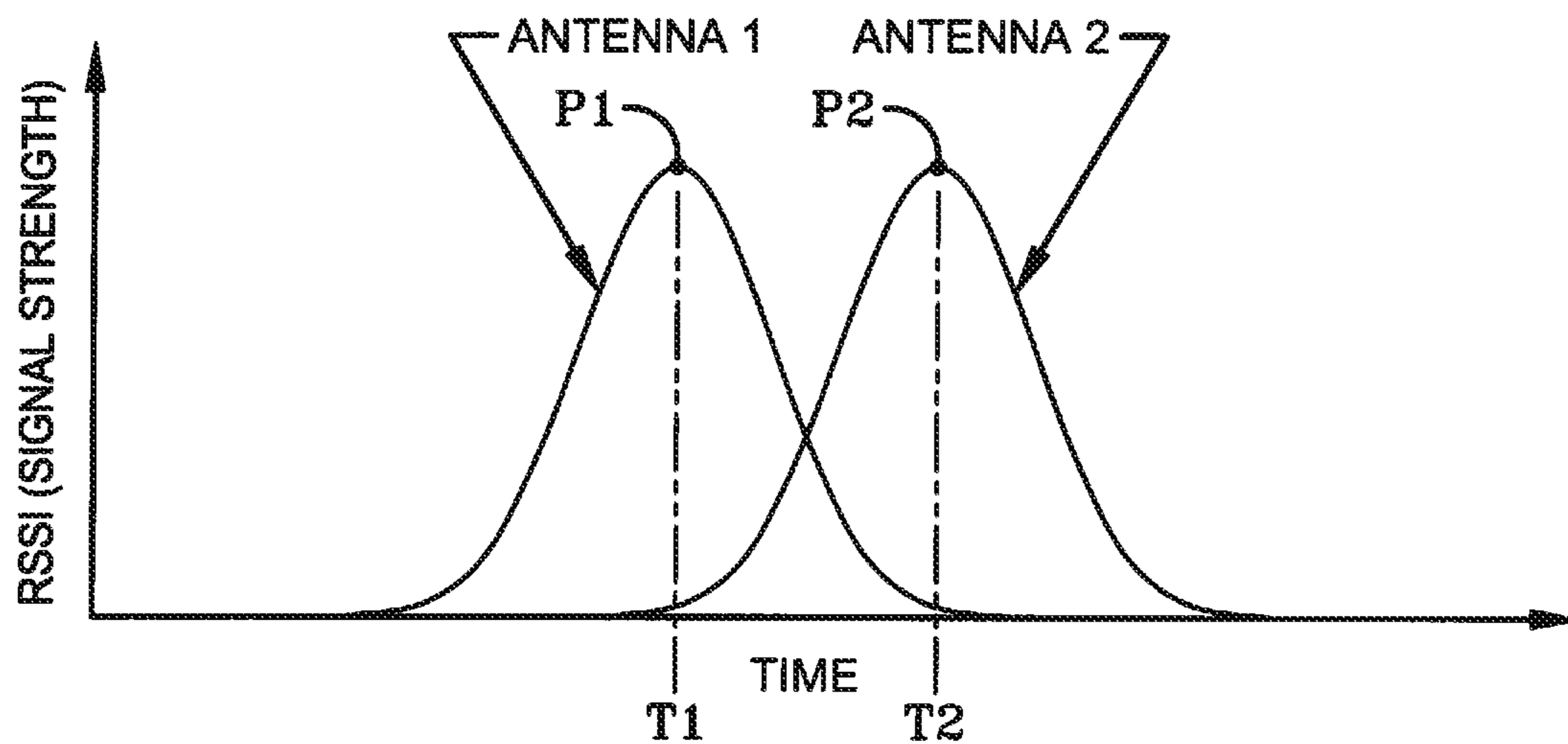

FIG-2

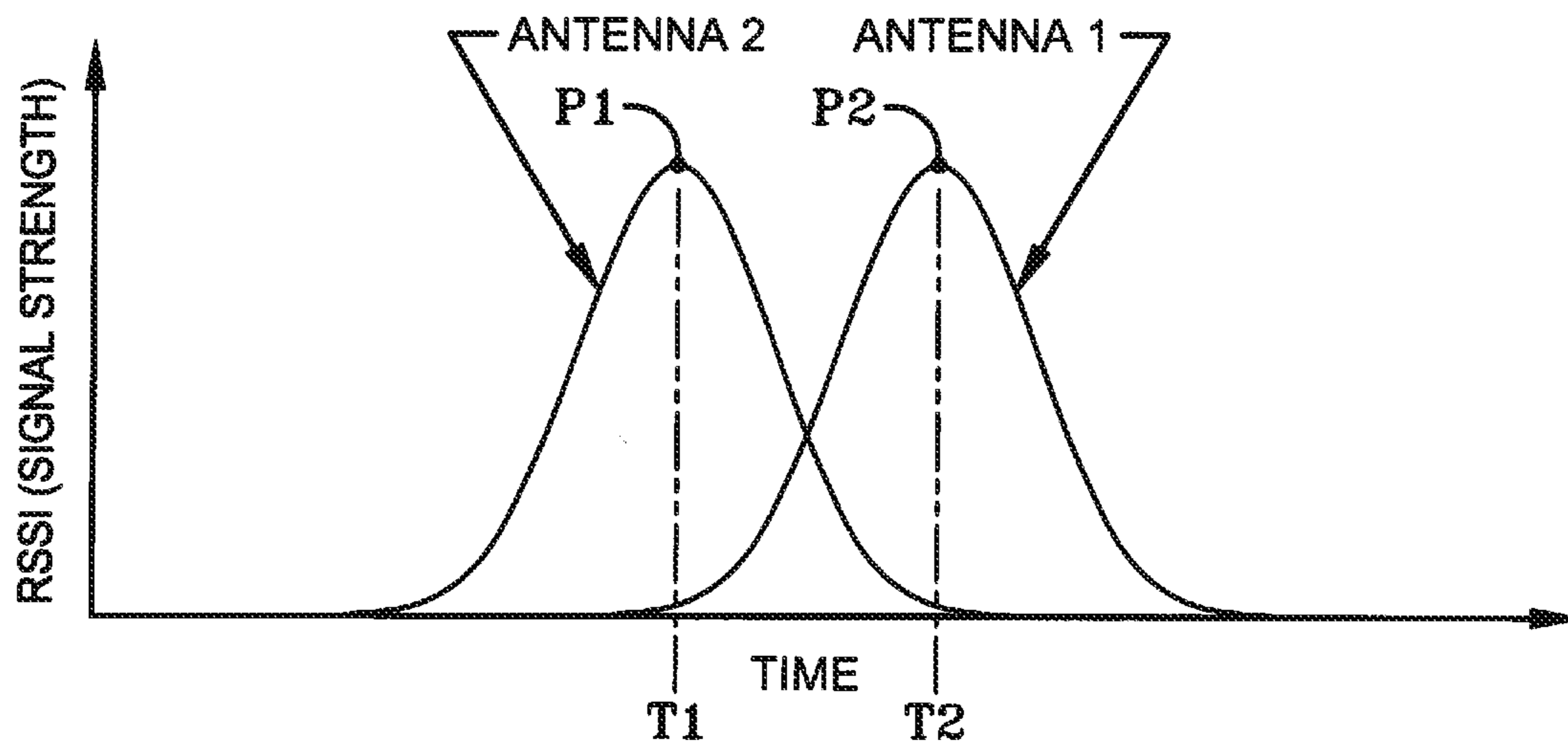
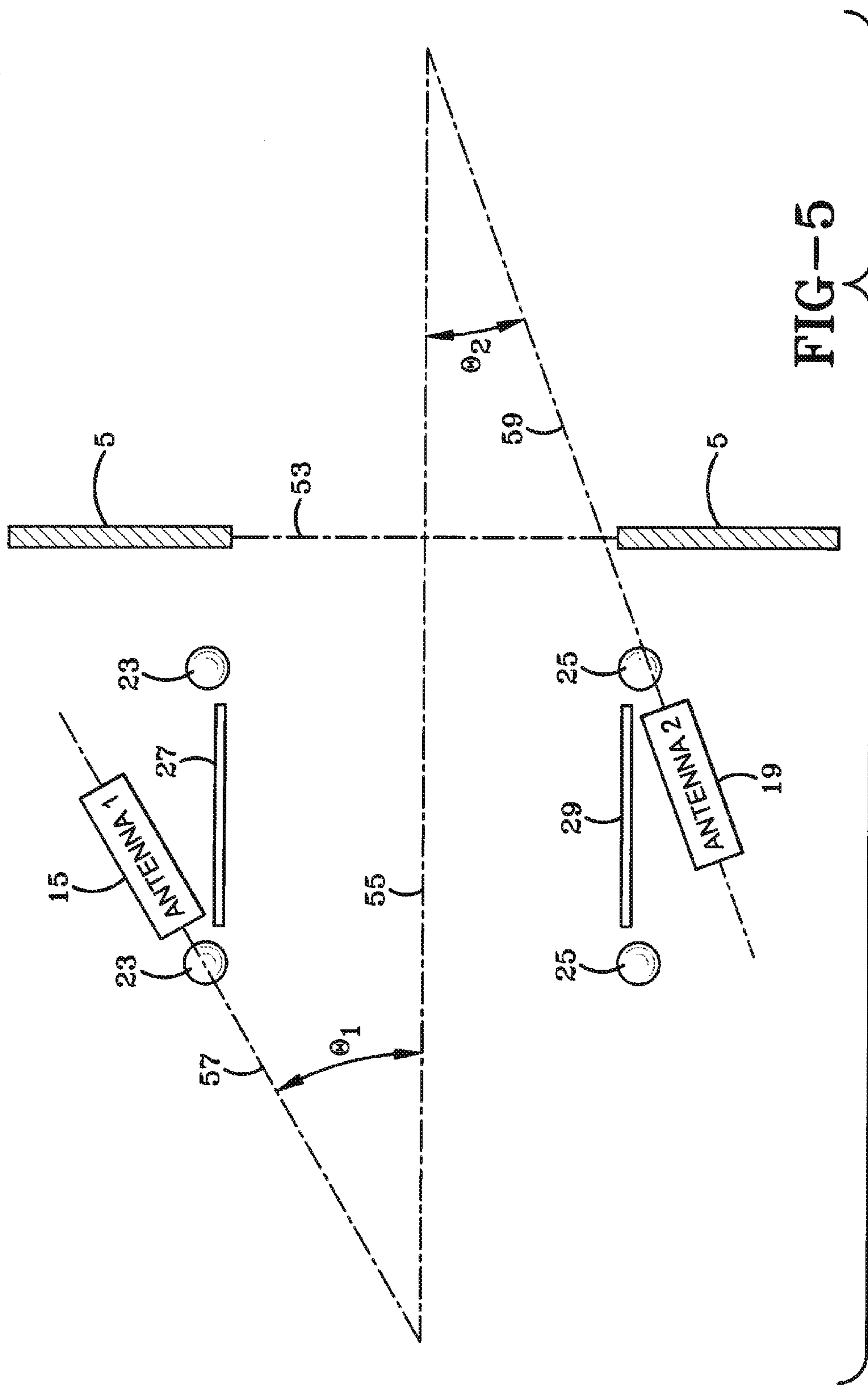

FIG-3

Item identifier	Antenna 1 peak time	Antenna 2 peak time	Loaded into warehouse	Loaded into vehicle	Expected Direction
00246	45A 45B 11:22:08:12	47A 47B 11:22:09:14	49A 49B Yes	51A 51B NULL	52A into warehouse
00247	45B 45C 11:23:10:45	47C 47D 11:23:11:47	49C 49D Yes	51C 51D NULL	52B into warehouse
00248	45C 45D NULL	47D 47E NULL	49E 49F NULL	51E 51F NULL	52C into vehicle
00249	45D 45E 11:25:03:12	47E 47F 11:25:01:81	49F 49G NULL	51G 51H Yes	52D into warehouse

FIG-4



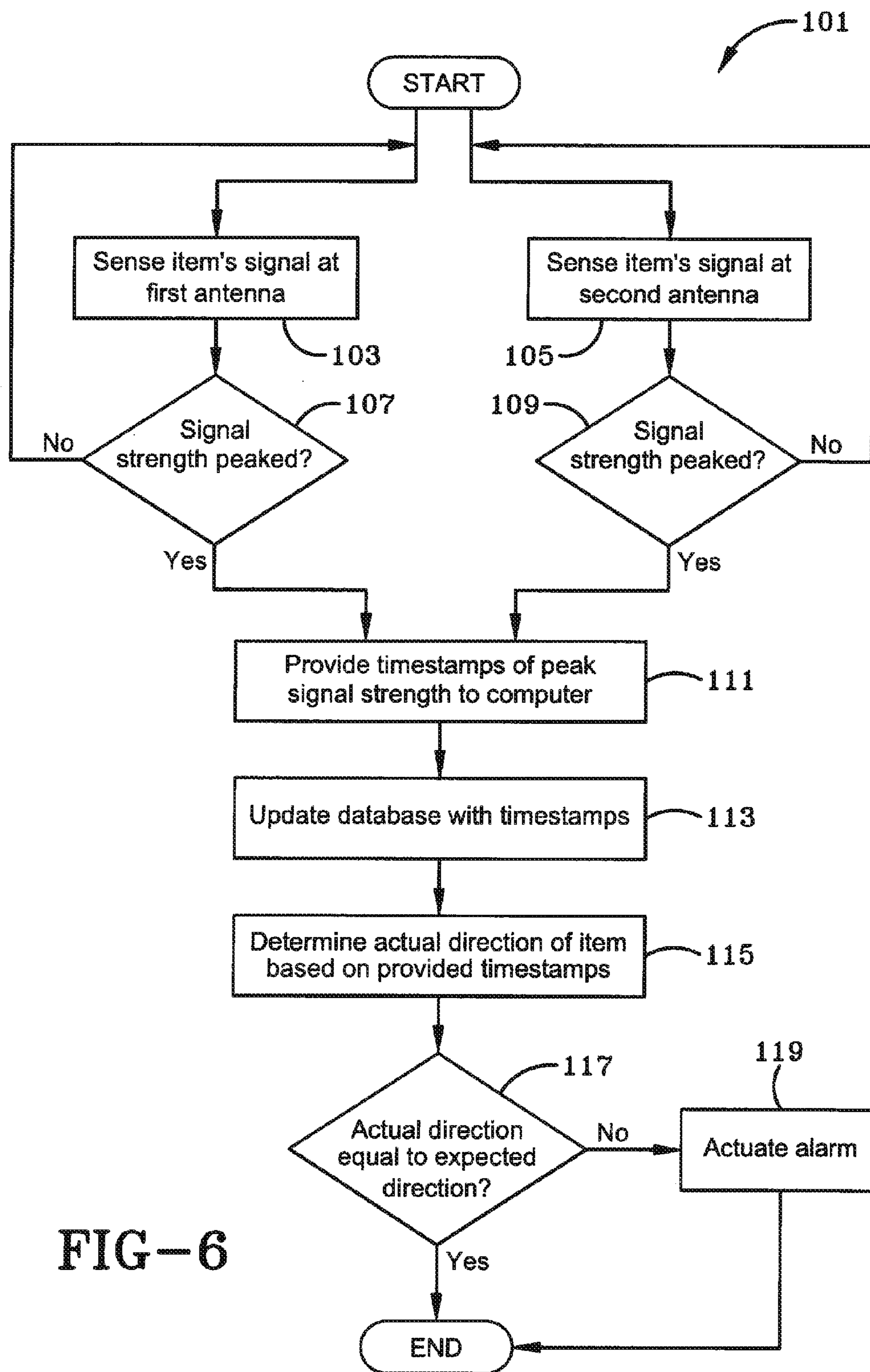

FIG-6

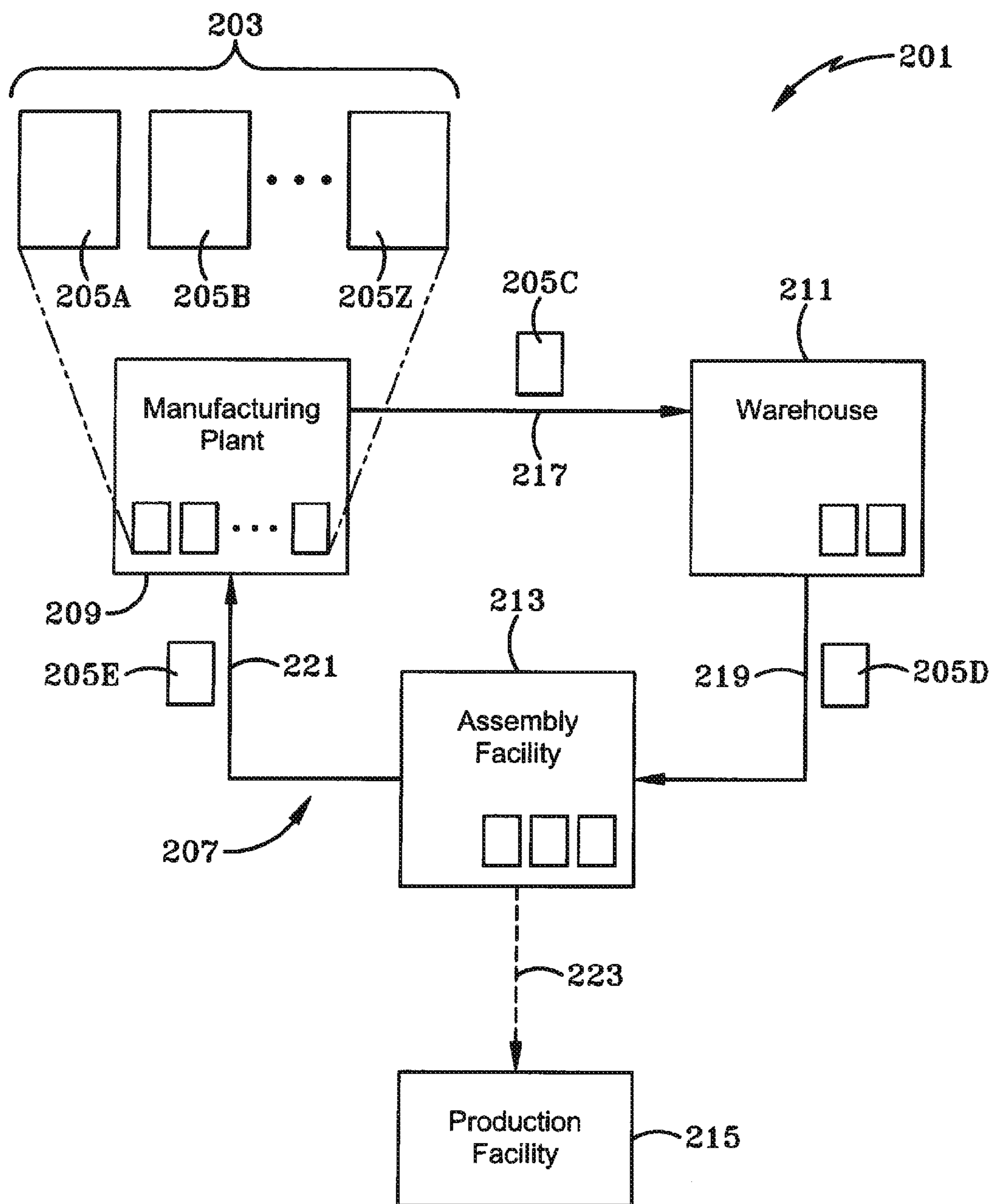

FIG-7

227

233

235

237

239

Locations Table		Current Average Dwell Time	Maximum Dwell Time
Key	Location Name		
1	Manufacturing plant	3.3 days	4 days
2	En route to warehouse from manufacturing plant	1.2 days	2 days
3	Warehouse	12.9 days	12 days
4	En route to assembly facility from warehouse	2.2 days	5 days
5	Assembly facility	3.4 days	5 days
6	En route to manufacturing plant	1.1 days	2 days

A
B
C
D
E
F

FIG-8

229

241

243

245

247

249

Asset Table				
Key	Tag Identifier	Current Location Key	Time In	Asset Type
1	899	1	10/9/2013	Large Bin
2	831	3	10/29/2013	Large Bin
3	345	3	10/23/2013	Small Bin
4	641	2	10/22/2013	Wheeled Rack
5	693	5	11/2/2013	Large Bin

A
B
C
D
E

FIG-9

231

251

253

255

257

259

261

Asset History Table

Key	Asset Key	Location Key	Time In	Time Out	Dwell Time
1	1	1	9/15/2013	9/18/2013	3 days
2	1	2	9/18/2013	9/19/2013	1 day
3	1	3	9/19/2013	10/1/2013	12 days
4	1	4	10/1/2013	10/3/2013	2 days
5	1	5	10/3/2013	10/7/2013	4 days
6	1	6	10/7/2013	10/9/2013	2 days
7	2	1	10/7/2013	10/9/2013	2 days
8	2	2	10/9/2013	10/10/2013	1 days
9	2	3	10/10/2013	10/21/2013	11 days
10	2	4	10/21/2013	10/25/2013	4 days
11	2	5	10/25/2013	10/29/2013	4 days

FIG-10

Common Database Queries	
Query	Answer
Q1 Average turn time for Asset 1 at Location 1?	24.2 days
Q2 Percentage of asset fleet passing through location 3 from 10/11/2013 to 10/19/2013?	42%
Q3 Current dwell time for Asset 3?	10 days
Q4 Current location of Asset 4?	En route to warehouse from manufacturing plant

FIG-11

262

Sample Dwell Times Report				
Asset ID	Location 1 Dwell Time	Location 2 Dwell Time	Location 3 Dwell Time	Location 4 Dwell Time
1	1 day	13 days	2 days	2 days
2	2 days	13 days	2 days	3 days
3	1 day	14 day	2 days	3 days
4	2 days	12 days	2 days	4 days
5	2 days	14 days	2 days	3 days
6	2 days	12 days	2 days	3 days
Average Dwell Time	1.667 days	13 days	2 days	3 days

FIG-12

263

265

267

269

271

Sample Production Schedule			
ID	Task	Predecessor(s)	Duration
1	Start	-	0 days
2	a	1	2 days
3	b	2	5 days
4	c	3	9 days

FIG-13

273

275

Asset Requirements at Manufacturing Plant 1																																				
23-Jul-13							30-Jul-13							6-Aug-13							13-Aug-13															
Asset Type	Su	M	Tu	W	Th	F	Sa	Su	M	Tu	W	Th	F	Sa	Su	M	Tu	W	Th	F	Sa	Su	M	Tu	W	Th	F	Sa	Su	M	Tu	W	Th	F	Sa	
Small Bin	4	4	4	4	5	5	5	5	4	4	4	4	6	6	6	6	6	9	9	9	9	9	9	9	9	9	9	9	9	9	9	9	9	9	9	9
Large Bin	7	7	7	7	7	7	7	7	7	7	7	7	8	8	8	8	8	12	12	12	12	12	12	12	12	12	12	12	12	12	12	12	12	12	12	
Wheeled Rack	1	1	1	1	1	1	1	1	1	1	1	1	1	1	1	1	1	5	5	5	5	5	5	5	5	5	5	5	5	5	5	5	5	5	5	
	279A	279B	279C	279D	279E	279F	279G	279H	279I	279J	279K	279L	279M	279N	279O	279P	279Q	279R	279S	279T	279U	279V	279W	279X	279Y	279Z	279AA	279AB	279AC	279AD	279AE	279AF	279AG			

277A

277B

277C

277D

FIG-14

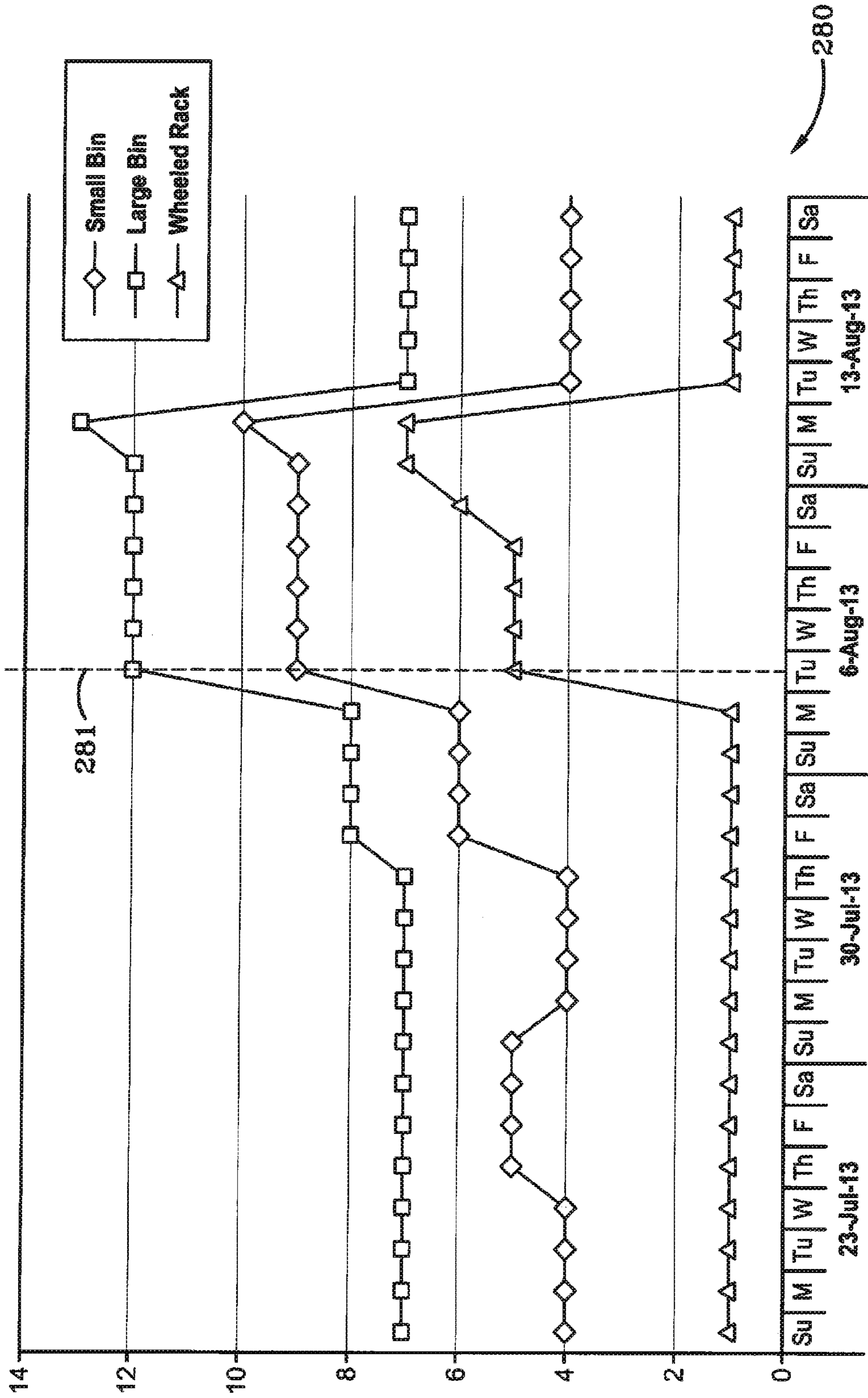

FIG-15

329

Key	Tag Identifier	Current Location Key	Time In	Asset Type Key	Sourcing Table Key	Sourcing Invoice
1	889	1	10/9/2013	3	2	[link A]
2	831	3	10/29/2013	3	2	[link B]
3	345	3	10/23/2013	1	1	[link B]
4	641	2	10/22/2013	4	1	[link C]
5	693	5	11/2/2013	3	4	[link D]

Asset Table

FIG-16

356

Key	Name	Height (cm)	Width (cm)	Length (cm)	Weight (kg)	Engineering Specification	Default Sourcing Table Key
1	Small Bin	25	25	25	10	[link A]	
2	Medium Bin	50	50	50	20	[link B]	
3	Large Bin	100	120	120	35	[link C]	
4	Wheeled Rack	42	50	150	143	NULL	
5	Small Pallet	10	35	90	80	[link E]	

Asset Type Table

FIG-17

Key	Company Name	Company Address	Primary Contact Person	Primary Contact Person Phone	Website URL
1	Hangzhou Plastics LTD	5100 Zhou Road, Hangzhou, China	Lu Tong	555-1234	www.sample-website1.com
2	Maple Leaf Tool & Die Company	6788 Main Street, Toronto, Canada	Larry Smith	555-1235	www.sample-website2.com
3	ASDF LLC	4321 James Street, Canton, Ohio, USA	Cincy Jones	555-1236	www.sample-website3.com
4	Beijing Total Maching Company	123 Mao Road, Beijing, China	Mark Tan	555-1237	www.sample-website4.com
5	LKJ & Sons Company	9090 Phillips Road, Iowa, USA	Michael McGee	555-1238	www.sample-website5.com

FIG-18

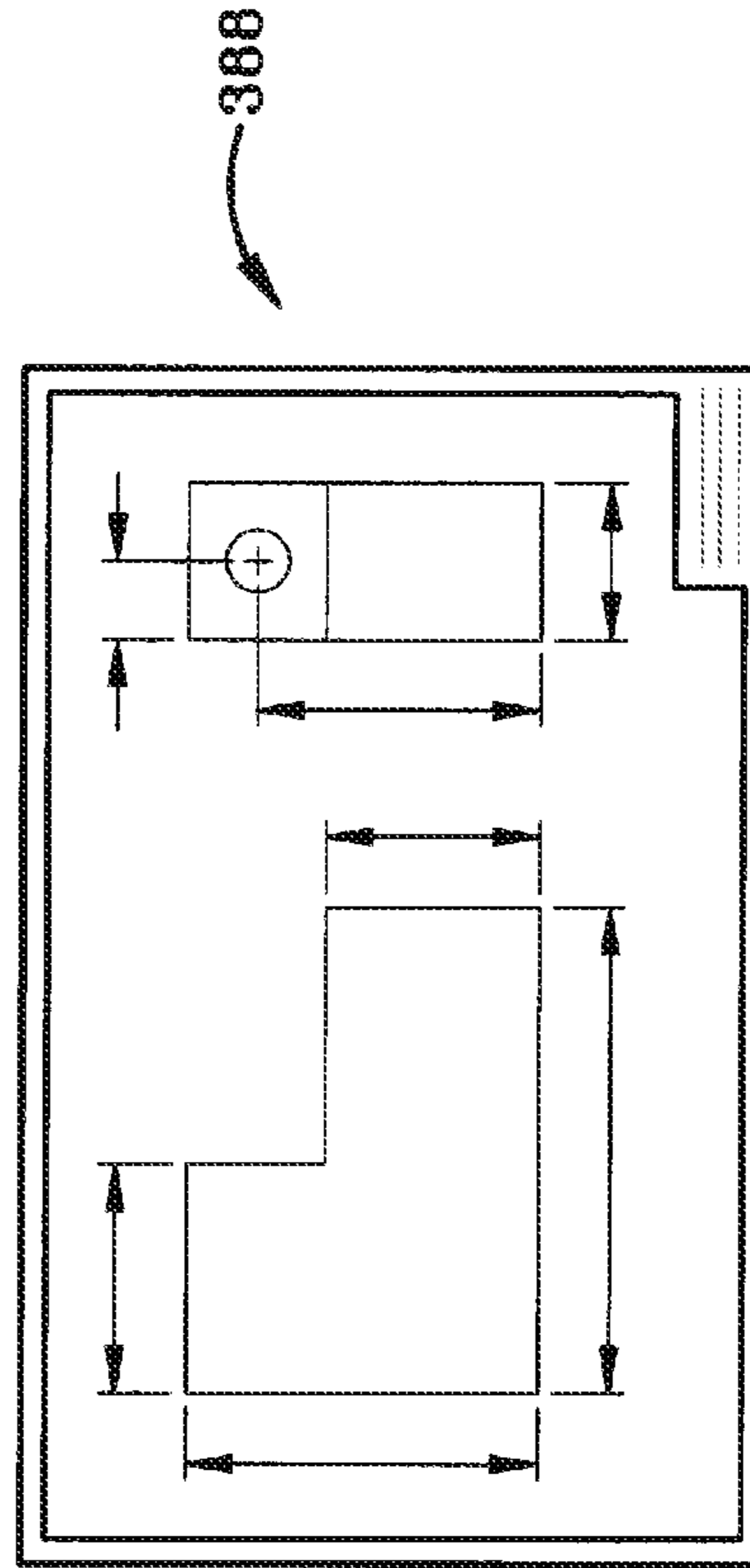

FIG-19

ASSET INFORMATION SYSTEM**CROSS REFERENCE TO RELATED APPLICATIONS**

[0001] This application is a continuation-in-part of U.S. patent application Ser. No. 14/171,130, filed Feb. 3, 2014, which is a continuation-in-part of U.S. patent application Ser. No. 14/096,466, filed Dec. 4, 2013; the disclosures of which are incorporated herein by reference.

BACKGROUND OF THE INVENTION

[0002] 1. Technical Field

[0003] The present invention relates to inventory management. More particularly, the present invention relates to tracking and maintaining inventory embodied as reusable assets in a supply chain. Specifically, the present invention relates to storing an engineering specification in a database and associating this engineering specification with an asset of the present invention to provide a streamlined mechanism for acquiring additional assets as desired.

[0004] 2. Background Information

[0005] Asset tracking and inventory management are complex components of most modern businesses. The tracking of inventory levels, orders, sales, and deliveries is critical to understanding the global picture of a company's inventory levels. Companies may use inventory management systems to avoid product overstock and outages. However, one critical underlying component of a robust inventory management system is a precise count and location of the inventory itself. Compounding the asset tracking problem is the problem of employee theft, which by some estimates accounts for over 60% of all inventory losses. Therefore, there is a critical need in the art for a system which not only tracks assets by keeping a precise count and location information for each inventory item, but also prevents theft of these assets.

[0006] Further, while assets may be embodied in commercial products for ultimate sale to the consumer, assets may also be embodied in reusable containers which are a costly company asset. When assets such as reusable containers are lost or misplaced within the supply chain, it adds additional costs in many ways. Either more containers must be purchased, ultimately oversizing a fleet and reducing effective utilization to undesired levels, or to meet demand, expendable packaging must be purchased, which creates immediate loss. Potentially, the worst cost of all is production stopping as a result of packaging shortages or misallocations of inventory. Therefore, companies desire to keep track of their reusable assets through the entire supply chain process. Further, companies have a critical need to identify loss, pinch points, dwell times, and generate turn analysis, as well as other metrics, such as real-time inventory counts and the location and activity data for all reusable assets. Broadly speaking, there is a critical need in the art for a system which provides an accurate picture of a company's packaging supply chain, inventory, loss, dwells, turns, and utilizations. Further, oftentimes companies do not have information relating to how and where they sourced a particular asset, or any information relating to the cost of the asset. This information is instrumental in quickly acquiring a new replacement asset in the event that an asset is lost or destroyed or has ended its lifecycle. Therefore, there is also a critical need to track and store information

relating to the original sourcing of an asset, including the engineering specification used to create the asset and invoice information.

BRIEF SUMMARY OF THE INVENTION

[0007] In one aspect, the invention may provide a method for predicting asset availability, the method comprising the steps of: providing a plurality of reusable assets, wherein each asset in the plurality of assets is sent away from the first entity, and wherein each asset in the plurality of assets is received back at the first entity; sensing when each asset in the plurality of assets is sent away from the first entity and updating a database with an incoming time; sensing when each asset in the plurality of assets is received back at the first entity and updating a database with an arrival time; calculating one of a dwell time for each asset in the plurality of assets and a turn time for each asset in the plurality of assets, wherein the dwell time is the time elapsed between the incoming time and the next outgoing time for each asset in the plurality of assets, and wherein the turn time is the time elapsed between the outgoing time and the next incoming time for each asset in the plurality of assets; constructing an asset requirements schedule for the first entity, wherein the asset requirements schedule specifies a required amount of assets in the plurality of assets required at the first entity for each successive increment of time in a plurality of increments of time; using the one of the dwell time and turn time for each asset in the plurality of assets to forecast a forecast amount of assets in the plurality of assets available at the first entity for each successive increment of time in the plurality of increments of time; and comparing the required amount of assets and the forecast amount of assets for each successive increment of time in the plurality of increments of time to determine whether the forecast amount of assets is sufficient for each increment of time.

[0008] In another aspect, the invention may provide a method for predicting asset availability, the method comprising the steps of: constructing an asset requirements schedule for use with a plurality of assets, wherein the asset requirements schedule specifies an amount of assets in the plurality of assets required at each location in a plurality of locations for each successive increment time in a plurality of increments of time; constructing an asset path schedule for use with the plurality of assets, wherein the asset path schedule specifies a series of locations in the plurality of locations for each asset in the plurality of assets, and wherein the series reflects the desired physical movement of the associated asset between locations in the plurality of locations; sensing when an asset in the plurality of assets arrives at a location in the plurality of locations, updating a database with an incoming time associated with the asset and the location and updating the database with a current location in the plurality of locations of the asset; sensing when the asset leaves the location and updating the database with an outgoing time associated with the asset and the location; calculating a dwell time for the asset at the location by comparing the incoming time and the outgoing time and associating the dwell time with the location; repeating the sensing and calculating steps to determine and associate at least one dwell time with each location in the plurality of locations; comparing the dwell times for each location in the plurality of locations, the current locations of each asset in the plurality of assets, and the asset path schedule to construct a model depicting a predicted location of each asset in the plurality of assets for each increment of time in the

asset requirements schedule; and comparing the model with the assets requirement schedule to predict whether the distribution of each asset in the plurality of assets at each location in the plurality of locations is sufficient for each increment of time in the asset requirements schedule.

[0009] In another aspect, the invention may provide a method for predicting asset availability, the method comprising the steps of: sending a plurality of assets between a plurality of locations in accordance with an asset path schedule; sensing when any asset in the plurality of assets is received at any location in the plurality of locations and storing a receipt timestamp and a current location in a database; sensing when any asset in the plurality of assets is sent from any location in the plurality of locations and storing a sent timestamp in the database; calculating a travel time for each asset in the plurality of assets between each location in the plurality of locations by comparing the receipt timestamp, sent timestamp, and current location for each asset in the plurality of assets at each location in the plurality of locations and storing the travel time in the database; calculating a dwell time for each asset in the plurality of assets between each location in the plurality of locations by comparing the receipt timestamp, sent timestamp, and current location for each asset in the plurality of assets at each location in the plurality of locations and storing the dwell time in the database; constructing an asset requirements schedule for use with the plurality of assets, wherein the asset requirements schedule specifies a required amount of assets of the plurality of assets required at each location in the plurality of locations for each increment of time in a plurality of increments of time; modeling the movement of each asset in the plurality of assets between locations in the plurality of locations for each increment of time in the plurality of increments of time by using the asset path schedule, dwell times, and travel times to determine when to model a particular asset in the plurality of assets moving to a particular location in the plurality of locations; comparing the modeled amount of assets in the plurality of assets with the required amount of assets in the plurality of assets for each increment of time in the plurality of increments of time; and notifying a higher authority if the comparing step determines a particular location in the plurality of locations is modeled to have less than the required amount of assets for a particular increment of time in the plurality of increments of time.

BRIEF DESCRIPTION OF THE SEVERAL VIEWS OF THE DRAWINGS

[0010] One or more preferred embodiments that illustrate the best mode(s) are set forth in the drawings and in the following description. The appended claims particularly and distinctly point out and set forth the invention.

[0011] The accompanying drawings, which are incorporated in and constitute a part of the specification, illustrate various example methods, and other example embodiments of various aspects of the invention. It will be appreciated that the illustrated element boundaries (e.g., boxes, groups of boxes, or other shapes) in the figures represent one example of the boundaries. One of ordinary skill in the art will appreciate that in some examples one element may be designed as multiple elements or that multiple elements may be designed as one element. In some examples, an element shown as an internal component of another element may be implemented as an external component and vice versa. Furthermore, elements may not be drawn to scale.

[0012] FIG. 1 is a top view of a delivery area of a structure incorporating the present invention;

[0013] FIG. 2 is a graph representing received signal strengths during an amount of time in the present invention;

[0014] FIG. 3 is a graph representing received signal strengths during an amount of time in the present invention;

[0015] FIG. 4 is a table showing exemplary data gathered and stored by the present invention;

[0016] FIG. 5 is a top view similar to FIG. 1, showing relative angles of antennas in the present invention;

[0017] FIG. 6 is a diagram depicting a method of the present invention;

[0018] FIG. 7 is a diagram depicting an exemplary supply chain topography with assets moving between locations;

[0019] FIG. 8 is a sample database table representing physical locations in the present invention;

[0020] FIG. 9 is a sample database table representing assets in the present invention;

[0021] FIG. 10 is a sample database table representing asset history in the present invention;

[0022] FIG. 11 is a sampling of common database queries in the present invention;

[0023] FIG. 12 is a sample report of dwell times at locations in the present invention;

[0024] FIG. 13 is a sample production schedule for use with the present invention;

[0025] FIG. 14 is a sample asset requirements schedule for use with the present invention;

[0026] FIG. 15 is a line graph depicting the information in the asset requirements schedule;

[0027] FIG. 16 is a sample database table representing assets in the present invention;

[0028] FIG. 17 is a sample database table representing asset types in the present invention;

[0029] FIG. 18 is a sample database table representing sourcing entities in the present invention; and

[0030] FIG. 19 is a sample engineering specification document in the present invention.

[0031] Similar numbers refer to similar parts throughout the drawings.

DETAILED DESCRIPTION OF THE INVENTION

[0032] A gate system is shown in FIGS. 1-5 and referred to generally herein as gate system 1. Various non-novel features found in the prior art relating to gate system 1 are not discussed herein. The reader will readily understand the fundamentals of electromagnetic wave propagation, antenna design, and signal processing are well within the prior art and readily understood by one familiar therewith.

[0033] Gate system 1 is adapted to work in conjunction with a building or structure 3 which includes a wall 5 defining an opening 7. Opening 7 is typically embodied in an entranceway into structure 3 at a loading dock area 9, and may be selectively sealable with a door (not shown). As typical in a loading dock, a truck 11 may be positioned proximate opening 7 with a platform 10 extended therefrom and through opening 7 for transferring items between truck 11 and structure 3. A forklift 13 is provided in FIG. 1 for reference and may be used to aid in transferring items between truck 11 and structure 3.

[0034] As shown in FIG. 1, a first antenna 15 is disposed within structure 3. First antenna 15 is preferably a directional antenna having a first radiation pattern 17 emanating therefrom in a particular direction. As shown in FIG. 1, first

antenna 15 is angled such that first radiation pattern 17 is angled generally towards opening 7. As commonly understood in the prior art, an item emanating a signal in the proper frequency will be received by first antenna 15 when the item is within first radiation pattern 17. Conversely, inasmuch as first antenna 15 is preferably a directional antenna, the signal will not be received by first antenna 15 when the item is outside of first radiation pattern 17. A second antenna 19 is also disposed within structure 3. Second antenna 19 is preferably a directional antenna having a second radiation pattern 21 emanating therefrom in a particular direction. As shown in FIG. 1, second antenna 19 is angled such that second radiation pattern 21 is angled generally away from opening 7. Similar to first antenna 15, any properly formatted signal emanating from an item within second radiation pattern 21 will be received by second antenna 19, as second antenna is preferably a directional antenna. Also similar to first antenna 15, second antenna 19 will not receive signals emanating from outside second radiation pattern 21.

[0035] First antenna 15 is positioned behind a first set of bumpers 23 while second antenna 19 is positioned behind a second set of bumpers 25. First set of bumpers 23 provide protection for first antenna 15 while second set of bumpers 25 provide protection for second antenna 19 and both sets of bumpers 23 and 25 are made from a sturdy material, such as steel or reinforced aluminum. Bumpers 23 and 25 are provided to protect antennas 15 and 19, respectively, as warehouses and stockroom areas are often chaotic with forklifts 13 and various other equipment such as dollies constantly moving thereabout. First antenna 15 is further positioned behind first shield 27 while second antenna 19 is further positioned behind second shield 29. While first set of bumpers 23 and second set of bumpers 25 are preferably metallic, first shield 27 and second shield 29 are preferably made from plastic or another similar material which efficiently facilitates the passing through of electromagnetic signals. First shield 27 and second shield 29 are formed from non-metallic material to allow first antenna 15 and second antenna 19 to send and receive signals therethrough.

[0036] As shown in FIG. 1, first antenna 15 is connected to a computer 33 by way of a first connection 31. First connection 31 may be a wired or wireless connection for providing a communications mechanism between a first antenna 15 and computer 33. Computer 33 may be any style of computing device, and may include a processor (not shown) coupled with a memory (not shown). Computer 33 is connected to a database 35 for storing information relevant to gate system 1. Computer 33 is also connected to an alarm 37 by way of an alarm connection 34. Alarm connection 34 may be a wired or wireless communication mechanism and provides for data communication between computer 33 and alarm 37. Alarm 37 may be any style of alarming type of system which includes an audible alarm, a silent alarm, or any other type of alert system, including alerting a particular personnel of building 3. Similar to first alarm 15, second alarm 19 is connected to computer 33 by way of a second connection 39. Second connection 39 may be a wired or wireless connection and provides a mechanism for transferring data between computer 33 and second antenna 19. First antenna 15 and second antenna 19 provide information and data relating to signals received thereby and transfers this data to computer 33 by way of first connection 31 and second connection 39, respectively.

[0037] As seen in FIG. 2, a graph is provided depicting signal strength in the Y axis and relative to a time duration in the X axis. As an item emanating a signal passes between first antenna 15 and second antenna 19, first antenna 15 and second antenna 19 receive the signal along with its varying signal strength as it passes through first radiation pattern 17 and second radiation pattern 21, respectively. This information is transferred to computer 33 by way of first connection 31 and second connection 39. Computer 33 processes this signal strength information which is represented graphically in FIG. 2. As shown in FIG. 2, the signal strength of the signal passing through first radiation pattern 17 of first antenna 15 gradually swells until peak P1 at time T1, then tapers off as time continues. This represents the item passing through first radiation pattern 17. As the item passes through first radiation pattern 17, the signal strength of the signal emanating therefrom grows as the item approaches its nearest point to first antenna 15. After the item passes this nearest point at time T1, the item moves away therefrom and the respective signal strength of the signal dissipates accordingly. The same scenario happens as the item passes second antenna 19. As shown in FIG. 2, the relative signal strength of the signal emanating from the item grows and swells to peak P2 at time T2 which reflects second antenna 19 positioned differently than first antenna 15. Computer 33 recognizes time T1 occurs before time T2 and thus deduces the item is moving past first antenna 15 first and past second antenna 19 second. It follows that item must be moving from the exterior of building 3 into the interior of building 3 in the direction of Arrow A (FIG. 1).

[0038] As shown in FIG. 3, second antenna 19 receives a peak signal P1 at time T1 while first antenna 15 receives a peak signal P2 at a time T2, which is later than time T1. This allows computer 33 to deduce that the item is traveling from the interior of building 3 towards loading dock area 9, in the direction of Arrow B (FIG. 1). As shown in FIGS. 2 and 3, computer 33 compares data from first antenna 15 and second antenna 19 and ensures there is an overlap of signal readings which is shown generally between T1 and T2. This signifies the item travelled through both radiation pattern areas, including first radiation pattern 17 and second radiation pattern 21. System logic may be implemented to ignore any incoming signals from only one antenna if computer 33 does not receive an overlapping signal as shown in FIGS. 2 and 3. These false positives may be triggered by merchandise being moved within truck 11 to make room for forklift 13 or any other reason merchandise may need to be moved yet not pass all the way through both radiation patterns. As shown in FIG. 4, a database table 41 is provided as an exemplary embodiment of data storage within database 35. Database table 41 stores data provided to computer 33 by first antenna 15 and second antenna 19. Database table 41 generally includes information relating to antenna signals generated by a particular item and the direction this item traveled through gate system 1. As such, a key column 43 is provided to represent unique identifiers correlated to an item needing to be tracked. A column 45 is provided for storing information relating to each item and the first antenna 15 peak time with respect to that item. Column 45 represents the time in which first antenna 15 receives the strongest signal from the associated item found in column 43. For example, with respect to FIG. 2, column 45 would store time T1 therein. Database table 41 also includes a column 47, which stores information relating to second antenna 19 peak time with respect to each item. For example, as shown in FIG. 2, column 47 would store time T2

therein. When a database row is created for a new item, a column 49 is set to null or no value therein. Similarly, when a new item is created in database table 41, a column 51 is created and also set to null or no data. Column 49 represents whether computer 33 determines the respective item was loaded into the warehouse. Similarly, column 51 represents the determination made by computer 33 as to whether the particular item found in column 43 was loaded into the vehicle. Database table 41 also includes an expected direction column 52. Column 52 indicates whether the row item is expected to be received into the warehouse or received into the truck. The data in this column may be maintained by the manufacturer or a global inventory management system or any other mechanism which may supply the data indicating where the item in that particular row should be received.

[0039] By way of example, populating a row of database table 41 is now described with respect to row A. Cell 43A of database table 41 is populated with an identification key representing an item intended for use with gate system 1. Specifically, cell 43A includes the entry '00246' which represents an item in database table 41. Cell 45A includes a time stamp of '11:22:08:12' which represents the precise time first antenna 15 received the strongest signal from the item. Cell 47A includes entry '11:22:09:14' which represents precisely when second antenna 19 received the strongest signal emanating from the item. One will recognize that the time stamp within cell 47A is about one second later than the time stamp in cell 45A. Thus, inasmuch as the timestamp for second antenna 19 is later than the timestamp for first antenna 15, computer 33 may deduce that item '00246' travelled in the direction of Arrow A (FIG. 1) and was received into building 3. Thus, computer 33 indicates in cell 49A that item '00246' was affirmatively loaded into building 3, overwriting the default null value which previously resided in cell 49A. Cell 51A remains set to null as computer 33 did not update this cell because item '00246' was not loaded into the vehicle according to the signals received by first antenna 15 and second antenna 19. Thereafter, item '00246' is accounted for and a user interested in any data relating to item '00246' may look at database table 41 and see that item '00246' was loaded into building 3 at approximately 11:22:09:14. One will readily recognize that a date column or more data may be added to database table 41 in conformance with any requirements a user or an implementor of gate system 1 may require.

[0040] System logic may be implemented to actuate alarm 37 when an item is indicated as already being either loaded into building 3 or loaded into truck 11 and first antenna 15 and second antenna 19 receive a signal emanating from this item indicating it is again moving. For example, if computer 33 determines item '00246' is being loaded into truck 11 having already been loaded into building 3, as shown in cell 49a, computer 33 may actuate alarm 37, as this would indicate the item is potentially being stolen or at least creating an anomalous situation. As such, database table 41 may also include column 52 relating to an expected direction in which the item is expected to travel within gate system 1. For example, item '00246' is associated with an expected direction of received "into warehouse," and first antenna 15 and second antenna 19 determine item '00246' is not moving in the expected direction, computer 33 may actuate alarm 37. This and other system logic may be implemented to utilize the data available via first antenna 15 and second antenna 19, particularly with respect to the direction the items are traveling within gate system 1.

[0041] As shown in FIG. 5, gate system 1 may include an imaginary line 53 extending parallel with wall 5. Gate system 1 may further include an imaginary line 55 extending perpendicularly to imaginary line 53. As shown in FIG. 5, each antenna in gate system 1 includes an imaginary longitudinal line extending therethrough. More particularly, first antenna 15 includes an imaginary first longitudinal line 57 extending therethrough while second antenna 19 includes an imaginary second longitudinal line 59 extending therethrough. First longitudinal line 57 extends at an angle theta 1 with respect to imaginary line 55. Similarly, second longitudinal line 59 extends at an angle theta 2 with respect to imaginary line 55. In a preferred embodiment of gate system 1, theta 1 is equal to approximately 30°, while theta 2 is equal to approximately 20°. Thus, one will readily recognize first antenna 15 is offset from the parallel relationship with second antenna 19 by about 10° in the preferred embodiment. When viewed with respect to FIG. 1, this allows the associated radiation patterns to overlap while still providing sufficient coverage of opening 7 and the internal areas of building 3.

[0042] As shown in FIG. 6, gate system 1 includes a method 101. Method 101 begins and simultaneously enters both a step 103 and a step 105. In step 103, the first antenna of the present invention senses an item's signal. Step 103 then moves to a step 107. In step 105, the second antenna of the present invention senses the item's signal. Step 105 then moves to a step 109. In step 107, a determination is made as to whether the sensed signal is at its peak signal strength. If it is, step 107 proceeds to a step 111. If the signal sensed in step 107 is not at its peak signal strength, step 107 proceeds back to step 103 to repeat the sensing process. In step 109, a determination is made as to whether the sensed signal is at its peak signal strength. If it is, step 109 proceeds to step 111. If the signal sensed in step 109 is not at its peak signal strength, step 109 proceeds back to step 105 to repeat the sensing process. Step 111 collects the timestamp collected by the first antenna and provided by step 107 and the timestamp collected by the second antenna and provided by step 109 and provides these two timestamps to the computer. Step 111 thereafter proceeds to a step 113. Step 113 updates the database by entering the two timestamps in the appropriate database table (s) associated with the item and proceeds to a step 115. In step 115, the computer determines the actual direction of the item based on the timestamp acquired from the first antenna and the timestamp acquired from the second antenna and proceeds to a step 117. Step 117 determines whether the actual direction is equal to the expected direction. If the actual direction is equal to the expected direction, step 117 proceeds to end method 101. If step 117 determines that the actual direction is not equal to the expected direction, step 117 proceeds to a step 119. In step 119, the alarm is actuated as the item is traveling in an unexpected direction which may indicate a theft situation or another anomaly. Step 117 thereafter proceeds to end method 101.

[0043] The present invention includes a method 201 adapted to work in conjunction with a plurality or a fleet 203 of assets 205 as they move throughout a supply chain 207. Assets 205 may be embodied in reusable containers which are costly and therefore extremely important in supply chain 207. As shown in FIG. 7, supply chain 207 is comprised of a plurality of physical structures coupled with routes extending therebetween as needed. As shown in FIG. 7, an exemplary supply chain 207 is comprised of physical structures such as a manufacturing plant 209 feeding assets 205 to a warehouse

211, which thereafter feeds assets **205** to an assembly facility **213**. Assembly facility **213** assembles products and passes these assembled products on to a production facility **215** run by a third party. Assembly facility **213** then passes assets **205** back to manufacturing plant **209** to complete the directed loop of assets **205** through supply chain **207**. Supply chain **207** further includes a plurality routes, whereby assets **205** move between physical structures by way of these routes. For example, as shown in FIG. 7, a route **217** extends between manufacturing plant **209** and warehouse **211**, a route **219** extends between warehouse **211** and assembly facility **213**, and a route **221** extends between assembly facility **213** and manufacturing plant **209**. Finally, a route **223** extends between assembly facility **213** and production facility **215**. Route **217**, route **219**, route **221**, and route **223** may be any commonly known method of moving goods from one physical location to another, including manual moving of assets **205**, movement using automobiles, airplanes, boats, or any combination of these. By way of example, a particular asset **205C** is shown moving along route **217** from manufacturing plant **209** to warehouse **211**. Similarly, a particular asset **205D** is shown moving along route **219** and a particular asset **205E** is shown moving along route **221**. In practice, routes may be unidirectional where an asset **205** is always sent from one physical structure to another, or bi-directional where an asset **205** may be sent back and forth between two physical structures. The set of physical locations and routes are hereinafter referred to generically as a plurality of locations **208**. A user may construct an asset path schedule for use with fleet **203** of assets **205**, wherein the asset path schedule specifies a series of locations **208** for each asset **205**, and wherein the series reflects the desired physical movement of the associated asset **205** between locations **208**. The asset path schedule may be incorporated by a user into method **201** or it may be deduced by other information available in method **201**.

[0044] Method **201** may utilize directional gate system **1** or similar at each physical structure. As such, each asset **205** is coupled with a tag **225** which emits a signal received by first antenna **15** and second antenna **19** as described above. As such, any asset **205** entering or leaving a physical structure is automatically sensed and processed and the direction of the particular asset **205** and a timestamp is stored in database **35**. Note that an instance of first antenna **15** and second antenna **19** is disposed at each physical location in supply chain **207** and are used thereby for sensing when an asset **205** enters or leaves the physical location.

[0045] Directional gate system **1** is preferably implemented using radio frequency identification technology, which is a non-line-of-site technology. Therefore, method **201** doesn't require the individual tags **225** to be facing a certain direction on assets **205**. Method **201** further doesn't require tags **225** to be exposed on a pallet. Method **201** with directional gate system **1** is quicker than a traditional barcode method as the reader can process hundreds of tags **225** at a time, unlike an employee seeking and manually scanning individual barcodes. As discussed above, by incorporating directional gate system **1** into method **201**, assets **205** are automatically determined to be either entering or leaving a physical structure and the database entry is stored in database **35** accordingly.

[0046] For reference, database **35** is a globally updatable and accessible database for use in storing and providing information in method **201**. Under method **201**, database **35** may include several database tables for use in storing and providing information required for the efficient use of method **201**.

As such, FIG. 8 portrays one embodiment of a table **227** containing data relating to the plurality of locations **208** which are comprised of the physical locations and routes defined by method **201**; FIG. 9 portrays one embodiment of a table **229** containing data relating to the assets defined by method **201**; and FIG. 10 portrays one embodiment of a table **231** containing data relating to the forecasting performed in method **201**.

[0047] As shown in FIG. 8, table **227**, hereinafter referred to as locations table **227**, includes unlimited rows with each row signifying one of the plurality of locations **208** in method **201**, and wherein each row includes four columns. Locations table **227** includes a column **233** which provides a unique reference key for every row in locations table **227**. Locations table **227** further includes a column **235** which provides a description of a location stored in locations table **227**. This description may be a string of characters in a "human readable" format for storing a quick reference one of the plurality of locations **208** in supply chain **207**, whereby locations **208** may be a physical structure or a route between physical structures. For example, cell **235A** describes the referenced location as "Manufacturing Plant," while cell **235B** describes the referenced location as "En route to warehouse from manufacturing plant." The data stored in column **235** is user entered and specific to each embodiment of supply chain **207**. As such, method **201** may provide an interface for prompting the user to enter and update data stored in table **227**, particularly the data in column **235** regarding location names. Each row in locations table **227** represents one of the plurality of locations **208** in database form. Locations table **227** further includes a column **237** which relates to the current average dwell time of assets **205** disposed at that particular location. Locations table **227** further includes a column **239** which relates to the maximum dwell time for assets **205** disposed at that particular location. The details of how columns **237** and **239** are populated are discussed in greater detail below.

[0048] As shown in FIG. 8, table **229**, hereinafter referred to as assets table **229**, includes unlimited rows with each row signifying an asset in method **201**, and wherein each row includes five columns. As such, assets table **229** represents fleet **203** in database form. Assets table **229** includes a column **241** which provides a unique reference key for every row in assets table **229**. Assets table **229** further includes a column **243** which provides the tag identifier of a particular tag **225** associated with a particular asset **205**. This may be an RFID identification token if tags **225** are embodied as an RFID tag, or any other way to provide a correlation between a particular tag **225** and a particular asset **205**. Assets table **229** further includes a column **245** which provides information as to the current location in the plurality of locations **208** of a particular asset **205**. This information is provided by way of one of the keys in column **233** of locations table **227**. With respect to relational database terminology, locations table **227** and assets table **229** are linked in that the primary keys of column **233** of locations table **227** populate column **243** of assets table **229** to indicate the particular location **208** of each asset **205**. For example, for asset **205** having the key of "2," the number "3" is disposed in cell **245B** of assets table **229**, which relates to key **233A** of locations table **227**. As shown in cell **235B**, the location name associated with key "3" is "Warehouse." Thus, the asset **205** with the key of "2" as shown in cell **241B** is currently residing at warehouse **211** of supply chain **207**, which is indicated by the data in cell **245B**.

[0049] As shown in FIG. 9, assets table 229 also includes a column 247. Column 247 is automatically populated with a timestamp generated by directional gate system 1 as assets 205 pass one or both of first antenna 15 and second antenna 19. As described above, first antenna 15 and second antenna 19 sense when a particular tag 225 moves past and generates a timestamp relating to this time. As discussed with directional gate system 1, the direction the particular asset 205 is moving as well as the timestamp may be calculated by sensing the signal strength of tag 225. The timestamp is passed to database 35 and stored in the cell of column 247 which is associated with the appropriate sensed tag identifier in column 243. The location information from either first antenna 15 or second antenna 19 is also provided to database 35 for storage in the cell of column 245 which includes the sensed tag. For example, first antenna 15 is disposed at assembly facility 213 and senses tag identifier “693” pass thereby, which according to asset table 229, indicates that asset 205 having the key “5” has passed thereby. First antenna 15 passes data relating to the exact time tag identifier “693” was sensed by first antenna 15 as well as the location of first antenna 15. In this example, database 35 updates the row of assets table 229 containing tag identifier “693” with the current location information and the generated timestamp. As shown in cell 245E, the current location is referenced as “5” which is correlates to “Assembly facility” in the locations table 227. Further, cell 247E is updated with the timestamp provided by first antenna 15 when asset “5” passed thereby.

[0050] Assets table 229 further includes a column 249 which includes information relating to the type of asset 205 that is represented by the database row. For example, asset 205 having the key “1” is indicated to be a “Large bin,” while asset 205 having the key “4” is indicated to be a “Wheeled rack.” This information is user generated and may alternatively be embodied in a separate database table of asset types. As such, column 249 may include foreign key references to the asset type table in such a configuration. Additional rows of assets table 229 may be added by a user or administrator anytime a new asset 205 is introduced into supply chain 207. Likewise, rows of assets table 229 may be deleted by a user or administrator anytime a particular asset 205 is retired from fleet 203.

[0051] As shown in FIG. 10, table 231, hereinafter referred to as asset history table 231, includes unlimited rows with each row relating to the movement of a particular asset into and out of a particular location 208 specified in locations table 227. In general, asset history table 231 keeps historical information in database form regarding the relationship between a particular asset 205 and a particular location 208, including the time the asset entered the location 208, the time the asset left the location 208, and the calculated dwell time of the particular asset 205 at that particular location 208. Pursuant to this, each row in asset history table 231 includes six columns. Asset history table 231 includes a column 251 which provides a unique reference key for every row of asset history table 231. In database terminology, the entries of column 251 are known as the “primary keys” for asset history table 231. Asset history table 231 further includes a column 253 which provides a foreign key reference to assets table 229, in particular a reference to one of the primary keys found in column 241 of assets table 229. This reference relates each row in asset history table 231 to a particular asset 205. Asset history table 231 further includes a column 255 which provides a foreign key reference to locations table 227, in particular a reference

to one of the primary keys found in column 233 of locations table 227. This reference relates each row in asset history table 231 to a particular location 208 in supply chain 207.

[0052] Asset history table 231 further includes a column 257 which provides information relating to when the particular asset 205 indicated in column 253 of the row was received into the particular location 208 indicated in column 255 of the row. In the exemplary embodiment, the information provided by column 257 is comprised of a timestamp provided by directional gate system 1. Similar to column 247 discussed above, column 257 is populated with a timestamp generated by directional gate system 1 as assets 205 pass one or both of first antenna 15 and second antenna 19. First antenna 15 and second antenna 19 sense when a particular tag 225 moves past and generates a timestamp relating to this time. As discussed with directional gate system 1, the direction the particular asset 205 is moving as well as the timestamp is calculated by sensing the signal strength of tag 225. This information is sent to database 35 and stored in column 257. Asset history table 231 further includes a column 259, which is similar to column 257. Column 259 provides information relating to when then particular asset 205 indicated in column 253 of the row was sent out from the particular location 208 indicated in column 255 of the row. In the exemplary embodiment, the information provided by column 259 is comprised of a timestamp provided by directional gate system 1 and is generated by the same underlying mechanics as described above for the information of column 257.

[0053] Asset history table 231 further includes a column 261 which provides information relating to the dwell time for the particular asset 205 indicated in column 253 of the row at the particular location 208 indicated in column 255 of the row. This information is derivable by taking the difference between when the particular asset 205 arrived at the particular location 208 and when the particular asset 205 left the particular location 208. As such, the information in column 261 for a particular row is derivable by taking the difference between the information in column 257 and column 259 for that particular row.

[0054] Once all of the columns for a particular row in table 231 are populated, the row and column data is generally not overwritten, updated, or deleted. Thus, table 231 provides a historical view of the information relating to how and when assets 205 move through supply chain 207. Reports and statistical analysis may be performed by extracting and manipulating the data stored in table 231. Reports may be generated indicating which location 208 in supply chain 207 is currently experiencing the greatest dwell time, or has the lowest average dwell time. Similarly, reports may be generated for a given date or time period to indicate which assets 205 were at what locations 208 during that time, or which locations 208 had beneficial dwell times, or any other available information. For example, a supply chain manager may wish to view which locations 208 are experiencing greater than acceptable dwell times for the past month. This information is readily available via a specially formatted database query using asset history table 231. The supply chain manager then may take managerial steps to address unacceptable dwell times at certain locations 208.

[0055] As shown in FIG. 11, various database queries may be formed and put forth to leverage the data stored in locations table 227, assets table 229, and asset history table 231. One important metric in method 201 are referred to as a “turn time.” Turn times are the amount of time a particular asset 205

takes to leave a particular location **208**, proceed through supply chain **207**, return to the particular location **208**, and proceed out again from the particular location. Turn times are readily deducible from querying asset history table **231** with a properly formatted database query. A human readable example of such a query is found in FIG. **11** as query Q1. Q1 asks “Average turn time for Asset 1 at Location 1,” with method **201** responding with an Answer A1, where A1 is provided as 24.2 days.

[0056] Another important metric in method **201** is referred to as a “shrink rate.” Shrink rate is the percentage of fleet **203** which has passed an antenna in directional gate system **1** during a particular time period. For example, method **201** may include a preformed data entry screen on a computer (not shown) connected to database **35** for reporting a shrink rate, with a prompt for the particular antenna and a prompt for the time range. The entered antenna and time range information is thereafter formed into a database query and sent to database **35**. The result is then displayed on the computer or printed or emailed for consideration by a user. A similar example is found in FIG. **11** as query Q2. Q2 asks “Percentage of asset fleet passing through location 3 from 10/11/2013 to 10/29/2013,” with method **201** responding with Answer A1, where A1 is provided as 42%. Note that Q2 asks for the percentage of fleet **203** passing through a location, rather than sensed by an antenna of directional gate antenna **1**, which is a slight variation on the shrink rate concept.

[0057] Various other queries may be formed to exploit the data in database **35** relating to locations table **227**, assets table **229**, and asset history table **231**. These queries may be in the form of user prompts on a computer screen with preformed query structures and text entry boxes or drop-down menus, or may be a free-form style of forming a specific query. For example, query Q3 asks for the “Current dwell time for Asset 3?” Q3 may be entered by a free form entry or by selecting menu options from an interface. As shown by an Answer A3, the current dwell time for Asset 3 is 10 days. Similar, Query Q4 asks for the “Current location of Asset 4?” As shown by an Answer A4, the current location of asset **4** is “En route to warehouse from manufacturing plant.” A4 is derived from accessing assets table **229**, selecting the row having key column **241** equal to “4,” which is cell **241D**. Database **35** then retrieves the foreign key of the current location in cell **245D**, which is “2.” The database **35** then selects the row of locations table **227** having “2” in key column **233**, which is cell **233B**. From this selected row, database **35** retrieves the location name from column **235**, which resides in cell **235B** and returns this to the user.

[0058] FIG. **12** shows an example dwell times report **262** which may be generated by method **201**. Dwell times report **262** shows an asset identification number for a sampling of assets **205** along with the most recently experienced dwell times at each location that particular asset **205** traveled. Report **262** further computes an average dwell time for each location by taking the average of all of the dwell times experienced by the assets **205** in the chart. In this sample, Location 1 has experienced a recent average dwell time of 1.667 days; location 2 has experienced a recent average dwell time of 13 days; Location 3 has experienced a recent average dwell time of 2 days; and Location 4 has experienced a recent average dwell time of 3 days. An asset manager or fleet supervisor would readily understand a bottleneck is occurring at Location 2, based on report **262**. The hard data provided by method

201 provides valuable feedback to supervisors or managers and valuable insight into the dwell times of the fleet with respect to each location.

[0059] As shown in FIG. **13**, a production schedule **263** may be entered into method **201** for use in conjunction therewith. Coupling production schedule **263** with method **201** enables method **201** to perform advanced planning and scheduling optimization and alert the users of supply chain **207** to any future bottlenecks or issues relating to assets **205** vis-a-vis the requirements of production schedule **263** and the current dwell times of all the locations **208** in the supply chain **207**. Method **201** may be formatted to accept a proprietary production schedule format or an industry standardized format for production scheduling, for example an Microsoft® Excel® sheet or a “Gantt Chart” style production schedule. Further, method **201** may allow a user to enter the production schedule into a user interface provided by method **201** to ensure data is entered into method **201** in a proper format. As shown in FIG. **13**, production schedule **263** is a simplified sample production schedule which may be entered into method **201**. A series of appropriate database tables and data storage is provided by method **201** for retaining the production schedule data. Production schedule **263** of FIG. **13** is formatted as a spreadsheet table having four columns. A column **265** includes an identification number for each task entry in production schedule **263**. Column **265** contains any style of unique identifier for referencing the task entry. A column **267** includes a task name for each task entry in production schedule **263**. The task names are human readable and easily identifiable alpha-numeric characters for providing a quick reference name or short description to a task, e.g. “load to dryer,” “dry solvents,” and “remove material from centrifuge.” A column **269** includes a predecessor task identification number for each task entry in production schedule **263**. The entries in column **269** provide the previous task identifier for which the current task depends and waits for completion. Finally, a column **271** includes a duration of time required to complete the associated task in production schedule **263**, e.g. “2 days,” or “5 days.” Similar production schedules may be formed and entered into method **201** to provide method **201** with information relating to when and where asset **205** are needed. Tasks may be associated with locations **208** manually or by including this information in production schedule **263** for use by method **201**.

[0060] As shown in FIG. **14**, a related asset requirements schedule or table **273** may be deduced from production schedule **263**. Alternatively, assets requirements schedule **273** may be entered into method **201** independently in addition to or in lieu of production schedule **263**. Asset requirements schedule **273** may be used by method **201** to compare the current number of assets **205** at all of locations **208** in supply chain **207** and determine any current or future inventory issues regarding whether enough assets **205** will be in place at each location **208** for each time in asset requirements schedule. The exemplary asset requirements schedule **273** provided in FIG. **14** portrays time units or increments in days and grouped by weeks for convenience. However, any unit or increment of time which is relevant to the user may be incorporated into asset requirements schedule **273**. As shown in FIG. **14**, assets requirements schedule **273** reflects asset **205** requirements by day at “Location 1.” For full implementation and accurate forecasting, an assets requirements schedule

273 must be provided for every location 208 in supply chain 207 so the entire scope of requirements may be considered with respect to fleet 203.

[0061] As shown in FIG. 14, asset requirements table 273 includes a column 275 for specifying what asset type is represented by the row, e.g. “large bin,” “small bin,” or “wheeled rack.” Rather than full character descriptions of asset types, a numerical identifier from Asset table 229 and column 241 may be used instead, e.g. “1” or “2,” etc. After column 241, four week columns 277 are provided, with each week column 277 having seven sub-columns, described hereinafter as day columns 279. Day columns 279 are directed to each day of the week for the week reflected in the associated week column 277. For example, week column 277A contains seven day columns 279A, 279B, 279C, 279D, 279E, 279F, and 279G. Each row under each day column 279 includes a number representing the number of assets 205 required at manufacturing plant 209 on the specified day for the asset reflected in column 275. For example, for the row specifying the asset type of “Small Bin,” as specified under day column 279C of week column 279A, seven (7) assets 205 which are in the form of a “small bin” are required at manufacturing plant 209 on the Tuesday of the week starting on Jul. 23, 2013.

[0062] Asset requirements table 273 specifies how many assets 205 and what kind of assets 205 are needed at a particular location 208 in supply chain 207 on a particular day. Further, inasmuch as asset requirements table 273 provides information regarding asset requirements into the future, method 201 may provide advanced planning and forecasting regarding management of fleet 203. Future asset 205 bottlenecks or asset shortages 205 are forecasted and decision makers may be alerted to the issue well in advance.

[0063] To forecast availability of assets 205, method 201 steps through each specified increment of time while simultaneously correlating the flow of assets 205 in fleet 203 using the aforementioned dwell times, turn times, and shrink rates for each asset 205 and location 208 in supply chain 207. For example, if a location A has three assets 205 at a time T1 and a location B has three assets 205 at time T1, using asset requirements table 273, method 201 looks up the number of assets 205 required at locations A and B at time T1 and determines whether the required number of assets 205 are presently at these locations. If not, method 201 alerts either the location A or B which has insufficient assets 205, or a system manager in charge of asset oversight, or any other actor in method 201 who may be responsible or able to act on the information regarding insufficient asset 205 allocation. Method 201 thereafter steps to the next increment (i) of time to consider the asset requirements of locations A and B at a time T1+i. However, method 201 also accounts for and predicts the movement of assets 205 based on the dwell times, turn times, and shrink rates for assets 205 and locations 208 in method 201. As discussed above, method 201 calculates and stores the current average dwell time and maximum dwell time for each location 208. Thus, as method 201 steps to the next increment of time, each asset 205 is considered vis a vis the current average dwell time and maximum dwell time for the location 208 they currently reside. If method 201 deduces that a particular asset 205 will likely move to the next location 208 in supply chain 207, method 201 models asset allocation at time T1+i with that asset moved to the next location 208 in supply chain 207.

[0064] Method 201 may include a threshold or another predictability algorithm or metric for determining how and

when to predict whether a particular asset 205 will move to the next location 208. These metrics can be tuned to the particular user or particular instance of method 201. For example, the underlying prediction algorithm may rely only on the maximum dwell time for each location 208 for predicting when a particular asset 205 will move to the next location. This is a conservative approach to predictive scheduling of the movement of assets 205 as this approach presupposes every asset 205 will spend the maximum time at a particular location 208 before moving to the next location. A less conservative approach incorporates the average dwell times rather than the maximum dwell times into the metrics used to predict asset 205 movement. A user may want to see a forecast of the both asset allocation algorithms with the conservative maximum dwell time approach juxtaposed with the less conservative average dwell time approach.

[0065] Regardless of the asset allocation scheme, once method 201 models the movement of assets 205 between locations, method 201 repeats the step of comparing assets 205 at a particular location 208 with the required number of assets 205 specified in asset allocation table 273. If a particular location 208 is found to be lacking in the required number of assets 205, method 201 alerts a user or whoever the specified decision maker is as to the deficiency. Thereafter, method 201 steps through the next increments of time, iteratively modeling the movement of assets 205 between locations 208 and thereafter determining if each location 208 is sufficiently supplied with at least the required number of assets 205. This is repeated for as far into the future as asset allocation table 273 provides.

[0066] The data of FIG. 14 is provided in a line chart 280 displayed in FIG. 15. One will readily note that asset requirements table 273 includes a spike in the requirements of all three asset types, wheeled rack, small bin, and large bin, on Tuesday of the week of Aug. 6, 2013. This is indicated by a dotted line 281 for clarity. The forecasting and asset allocation modeling of method 201 may provide a warning or valuable insight into increased production requirements when data such as that found in asset requirements table 273 is incorporated therein. Method 201 incorporates future increased rates or requirements into the modeling of future asset 205 movement and comparing the modeled distribution of each asset 205 with the asset requirements schedule. Thus, method 201 provides predictive modeling even in chaotic future environments and allows the users or higher authorities to make changes or adapt early to any future asset 205 shortages. These changes may include proactive movement of assets 205 or even acquiring additional assets 205 to meet the future demand.

[0067] With reference to assets table 229 and FIG. 9, as discussed previously, assets table 229 includes a column 249 which contains information relating to the type of asset 205 that is represented by that particular database row. While FIG. 9 and asset table 229 provides a text based entry in column 249, this information may alternatively contain a reference key to a separate database table reflecting all of the different asset types. This alternative embodiment is shown in FIG. 16 as an asset table 329. Asset table 329 is similar to asset table 229 shown in FIG. 9 in most respects, including columns 241, 243, 245, and 247. However, asset table 329 includes a column 349 in place of column 249. Column 349 contains a key reference to an asset type table 356 (FIG. 17). Asset table 329 further includes a column 350, which contains a key reference to a sourcing table 374 (FIG. 18). Finally, asset table 329

includes a column **352**, which contains information relating to the invoice associated with sourcing the asset **205** represented by that particular row. The invoice may be stored inside database **35** as a binary large object, known as a “blob,” which is a collection of binary data stored as a single entity inside database **35**. Alternatively, column **352** may contain a reference to the invoice, which may be in the form of a file system path description or a link to a digital version of the invoice which is stored on the local or remote file system. Alternatively, column **352** may contain a simple text based entry reflecting the invoice number which may be used to look up the invoice in a separate system.

[0068] With respect to the storage or reference to invoices in asset table **229**, inasmuch as multiple assets **205** may be sourced from the same entity and be reflected on the same invoice, the entries found in column **352** may be repeated as necessary for one or more rows to reflect the sourcing. For example, asset **205** represented by the row containing “2” in column **241** provides a link to the underlying invoice reflecting the sourcing of that asset, represented as “[link B]”. Asset **205** represented by the row containing “3” in column **241** also contains “[link B]” in column **242**. Thus, one will readily recognize that these two assets were billed on the same invoice.

[0069] As shown in FIG. **17**, asset type table **356** includes eight columns and generally defines an asset type with each row. Asset type table **356** includes a column **358**, which contains a unique identifier or key for that row. Asset type table **356** includes a column **360**, which contains a name for that particular type of asset **205**. Names may be a character based free-form entry or short hand for the type of asset. Examples such as “Small Bin,” “Large Bin,” and “Small Pallet” are shown for reference. Asset type table **356** includes a column **362**, a column **364**, and a column **366**, which contains the height, width, and length, respectively, of that particular asset **205**. This information is useful for shipping and packing the asset **205**, as well as planning for storage space and warehousing of the particular asset **205**. Asset type table **356** further includes a column **368** which contains information relating to the weight of the asset **205** represented by that row. This information is useful for calculating shipping weight and the costs involved therewith.

[0070] Asset type table **356** further includes a column **370**. Column **370** contains information relating to the engineering specification used to produce the particular asset **205** represented by that particular row. The engineering specification may be stored inside database **35** as a binary large object (“blob”) as a single entity inside database **35**. Alternatively, column **370** may contain a reference to the engineering specification, which may be in the form of a file system path description or a link to a digital version of the invoice which is stored on the local or remote file system. For example, asset **205** represented by the row containing “1” in column **370** provides a link to the underlying engineering specification document, represented as “[link A]”. Alternatively, column **370** may contain the actual binary representation of the engineering specification document, ready to be directly provided by database **35** as the result of a query or database request. An exemplary embodiment of an engineering specification **388** is shown in FIG. **19**. Engineering specification **388** includes drawings, measurements, size information, material information, and generally any information necessary for producing and manufacturing a particular asset **205** having a desired asset profile. Engineering specification **388** may be an

exported software file from using computer-aided design software (CAD) to create the engineering specification. Engineering specification **388** may be used by any competent manufacturer to build and manufacture an asset **205** having the desired asset profile reflected in engineering specification **388**.

[0071] In light of the above, asset type table **356** further includes a column **372** which contains a reference key to a row of sourcing table **374**. This reference is to provide a default sourcing entity for that particular asset **205** contained in the particular row. This information may be helpful to a manager of assets **205** by providing the typical or default entity from which the asset **205** is sourced from. As will be discussed in greater detail below, column **374** may be used to automatically source the associated asset **205** in the event that the underlying asset **205** becomes lost, destroyed, missing or otherwise retired.

[0072] As shown in FIG. **18**, sourcing table **374** includes six columns and generally defines a sourcing entity with each row. A sourcing entity may be a third party, completely separate from the overall entity building, or using, or maintaining gate system **1** or method **201** or any of the processes described herein. Alternatively, sourcing entity may be a corporate partner or a manufacturing division of a company. Broadly speaking, as used herein, a sourcing entity refers to any entity which potentially may manufacture, produce, and/or deliver a given asset **205** when requested. In order to represent a sourcing entity in database **35**, sourcing table **374** includes a column **376** which contains a unique identifier or key for each row. This key may be referenced by other tables in database **35** to connect the row of that table with the corresponding row in sourcing table **374**. For example, as shown in FIG. **16**, column **349** of row **3** specifies the sourcing entity for the asset **205** represented by that row is the sourcing entity having the reference key of “1.”

[0073] Sourcing table **374** further includes a column **378** which contains a sourcing entity’s name or company name; a column **380** which contains the sourcing entity’s corporate mailing address; and a column **382** which contains the name of a primary contact person at the sourcing entity for use in communicating with the sourcing entity. Sourcing table **374** further includes a column **384** which includes the primary contact person’s phone number. Finally, sourcing table **374** includes a column **386** which contains information relating to the website of the sourcing entity or company. While the six columns of sourcing table **374** are described herein, the present invention encompasses any subset of these columns or any expansion or additional columns which may be needed to help define a sourcing entity.

[0074] With specific reference to FIGS. **16-18**, one will readily recognize that any given asset **205** is tied to the specific sourcing entity which originally provided the asset **205**. Further, the sourcing entity’s name, address, contact person, contact phone number, website, and any other information tied to sourcing table **374** may be provided to the user upon request or query of database **35**. The invoice reflecting the sourcing of that asset **205** is further available for a user to review the cost involved with sourcing another asset **205**. Inasmuch as engineering specifications **388** are also stored in database **35** and keyed to all relevant assets which include that asset profile, a user can quickly provide engineering specification **388** to any sourcing entity that the user selects to source an addition asset **205**. One will readily understand that developing and designing a particular asset **205** is a costly endeavor

and any engineering specification **288** associated therewith is an important document to track and store. While many sourcing entities themselves may keep a copy of engineering specification **388** of a previously sourced asset **205**, over time, the sourcing entity may lose or misplace the engineering specification or the sourcing entity may cease operations or close. Asset holders themselves may also keep a copy of the engineering specification, but the present invention encompasses tying the management of assets **205** with the storage and linking of the underlying engineering specification. In this way, asset table **329** (FIG. **16**), asset type table **356** (FIG. **17**), and sourcing table **374** are interconnected using reference keys and provides a user a single point of contact with which to organize assets **205**, including determining their current location, original sourcing entity, and potential sourcing entities should an asset **205** need replaced.

[**0075**] Empowered by the above referenced information, a user of gate system **1** or method **201** may make strategic decisions regarding fleet **203** of assets **205** as they move through supply chain **207**. As described above, gate system **1** and method **201** may be used to monitor the total size of fleet **203** and alert a user if one asset **205** is missing or has ceased to be sensed by gate system **1**. In this event, the user may quickly and efficiently order a new replacement asset **205** by using the sourcing information found in asset type table **356** or sourcing table **374**. Specifically, the user may selected the particular engineering specification **388** associated with the missing asset **205** to recreate the asset profile and precisely replace the missing asset **205**. The user may also view the sourcing entity used in the sourcing of the missing asset **205** as well as view the invoice associated with the missing asset **205** to determine the previous price paid. This information may be helpful in determining where to source a replacement asset **205** and what the user should expect for a general cost involved. In this way, the user may easily order or source another asset **205** having the same asset profile as the lost or missing asset **205** and replenish fleet **203**. In addition to losing a particular asset **205**, gate system **1** or method **201** may include a timeframe variable or expiration date associated with the particular asset **205** in database **35**. A determination is made as to whether the timeframe has expired or the expiration date has passed for the associated particular asset **205**. If so, the user may order or source another asset **205** having the same asset profile as the retiring asset **205**. A user may even implement a procedure to manually inspect one or more assets **205** in fleet **203** and determine whether a particular asset **205** needs replaced by ordering or sourcing a new asset **205**.

[**0076**] All of the above issues relate to assets **205** in fleet **203** and keeping the size of fleet **203** to at least a minimum inventory level. As such, the methods discussed previously with respect to constructing asset requirements schedule **273** for use with fleet **203** and specifying the amount of assets **205** required at each location **208** for each successive increment of time in asset requirements schedule **273**. These elements are used to construct a model of the distribution of assets **205** in fleet **203** into the future. If the user determines that an insufficient amount of assets **205** exist in fleet **203** for any future increment of time, the user may then order or source one or more additional assets **205** by using the sourcing information found in asset type table **356** or sourcing table **374**. In this way, the user can ensure enough assets **205** are available to meet the needs well into the future.

[**0077**] “Logic,” “logic circuitry,” or “logic circuit,” as used herein, includes but is not limited to hardware, firmware, software and/or combinations of each to perform a function (s) or an action(s), and/or to cause a function or action from another logic, method, and/or system. For example, based on a desired application or needs, logic may include a software controlled microprocessor, discrete logic like a processor (e.g., microprocessor), an application specific integrated circuit (ASIC), a programmed logic device, a memory device containing instructions, or the like. Logic may include one or more gates, combinations of gates, or other circuit components. Logic may also be fully embodied as software. Where multiple logics are described, it may be possible to incorporate the multiple logics into one physical logic. Similarly, where a single logic is described, it may be possible to distribute that single logic between multiple physical logics.

[**0078**] Example methods may be better appreciated with reference to flow diagrams. While for purposes of simplicity of explanation, the illustrated methodologies are shown and described as a series of blocks, it is to be appreciated that the methodologies are not limited by the order of the blocks, as some blocks can occur in different orders and/or concurrently with other blocks from that shown and described. Moreover, less than all the illustrated blocks may be required to implement an example methodology. Blocks may be combined or separated into multiple components. Furthermore, additional and/or alternative methodologies can employ additional, not illustrated blocks.

[**0079**] In the foregoing description, certain terms have been used for brevity, clearness, and understanding. No unnecessary limitations are to be implied therefrom beyond the requirement of the prior art because such terms are used for descriptive purposes and are intended to be broadly construed.

[**0080**] While the present invention has been described in connection with the preferred embodiments of the various figures, it is to be understood that other similar embodiments may be used or modifications and additions may be made to the described embodiment for performing the same function of the present invention without deviating there from. Therefore, the present invention should not be limited to any single embodiment, but rather construed in breadth and scope in accordance with the recitation of the appended claims.

1. A method for ensuring asset availability, the method comprising the steps of:
 - sourcing a first asset having an asset profile using an engineering specification;
 - entering the engineering specification into a database;
 - determining whether the first asset needs replaced; and
 - retrieving the engineering specification from the database and using the engineering specification to source a second asset having the asset profile when the determining step determines the first asset needs replaced.
2. The method of claim **1**, further comprising the steps of:
 - applying an electronic tag to the first asset;
 - tracking the first asset by sensing the electronic tag with a plurality of antennas; and
 - determining the first asset needs replaced when the plurality of antennas cease sensing the electronic tag.
3. The method of claim **1**, further comprising the steps of:
 - entering a timeframe into the database; and
 - determining the first asset needs replaced when the timeframe has expired.

4. The method of claim 1, further comprising the steps of: entering an expiration date into the database; and determining the first asset needs replaced when the expiration date is passed.
5. The method of claim 1, further comprising the steps of manually inspecting the first asset to determine whether the first asset needs replaced.
6. The method of claim 1, further comprising the step of using computer-aided design software to create the engineering specification.
7. The method of claim 1, further comprising the step of sourcing the second asset from a third party.
8. The method of claim 1, further comprising the step of introducing the first asset into a fleet of assets, wherein each asset in the fleet of assets conforms to the asset profile.
9. The method of claim 8, further comprising the steps of: determining whether the fleet of assets requires an additional asset; retrieving the engineering specification from the database when the determining step determines the fleet of assets requires an additional asset; and using the engineering specification to source the additional asset.
10. The method of claim 1, further comprising the step(s) of: receiving an invoice reflecting the sourcing of one of the first asset and the second asset; entering the invoice into the database; and associating the invoice with the one of the first asset and the second asset in the database.
11. A method for predicting asset availability, the method comprising the steps of: sourcing a plurality of assets, wherein each asset in the plurality of assets conforms to an asset profile, and wherein the asset profile is defined by an engineering specification; storing the engineering specification in a database; and associating the engineering specification with the plurality of assets in the database.
12. The method of claim 11, further comprising the steps of: sensing when an asset in a plurality of assets arrives at one of a plurality of locations; updating the database with an incoming time associated with the asset and the location; sensing when the asset leaves the location; and updating the database with an outgoing time associated with the asset and location.
13. The method of claim 12, further comprising the steps of: calculating a dwell time for the asset at the location by comparing the incoming time and the outgoing time; and

updating the database with the dwell time associated with the asset and the location.

14. The method of claim 13, further comprising the step of repeating the sensing and calculating steps to determine and associate a dwell time for every asset in the plurality of assets with respect to every location in the plurality of locations.

15. The method of claim 14, further comprising the step of using the incoming times to determine a current location for every asset in the plurality of assets.

16. The method of claim 15, further comprising the steps of:

constructing an asset requirements schedule for use with the plurality of assets; and

specifying in the asset requirements schedule an amount of assets in the plurality of assets required at each location in the plurality of locations for each successive increment of time in a plurality of increments of time.

17. The method of claim 16, further comprising the steps of:

constructing an asset path schedule for use with the plurality of assets; and

specifying in the asset path schedule a series of locations in the plurality of locations for each asset in the plurality of assets; and

reflecting a desired physical movement of the associated asset between locations in the plurality of locations in the series.

18. The method of claim 17, further including the step of comparing the dwell times for each location in the plurality of locations, the current location for each asset in the plurality of assets, and the asset path schedule to construct a model depicting a predicted location of each asset in the plurality of assets for each increment of time in the asset requirements schedule.

19. The method of claim 18, further including the steps of: comparing the model with the assets requirements schedule; and

determining whether the modeled distribution of each asset in the plurality of assets at each location in the plurality of locations is less than the amount specified in the asset requirements schedule for each increment of time in the plurality of increments of time.

20. The method of claim 19, further including the step of sourcing additional assets by providing the engineering specification to a sourcing entity if the modeled distribution of each asset in the plurality of assets at each location in the plurality of locations is less than the amount specified in the asset requirements schedule for any one increment of time in the plurality of increments of time.

* * * * *